

SKU #	Radiator DWG #	Radiator P/N	Transmission	Core Size	Shroud & Fan DWG #	Shroud & Fan P/N	Fan Type
1-1640-102BLX	1-1640-Radiator	1-1640-100	Manual	STANDARD (2 Rows of 1" Tubes)	1-1640-002BLX (Dual Chamber Shroud)	1-1640-002BLX	300 Watt Brushless
1-1640-112BLX		1-1640-110	Automatic				
1-1640-202BLX		1-1640-200	Manual	UPGRADED (2 Rows of 1.25" Tubes)			
1-1640-212BLX		1-1640-210	Automatic				

REVISIONS				
ZONE	REV	DESCRIPTION	DATE	APPROVED

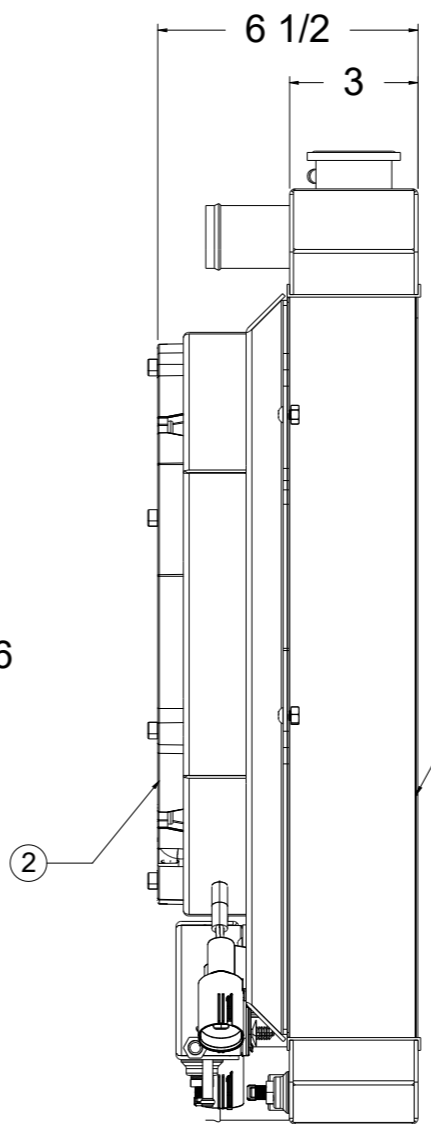
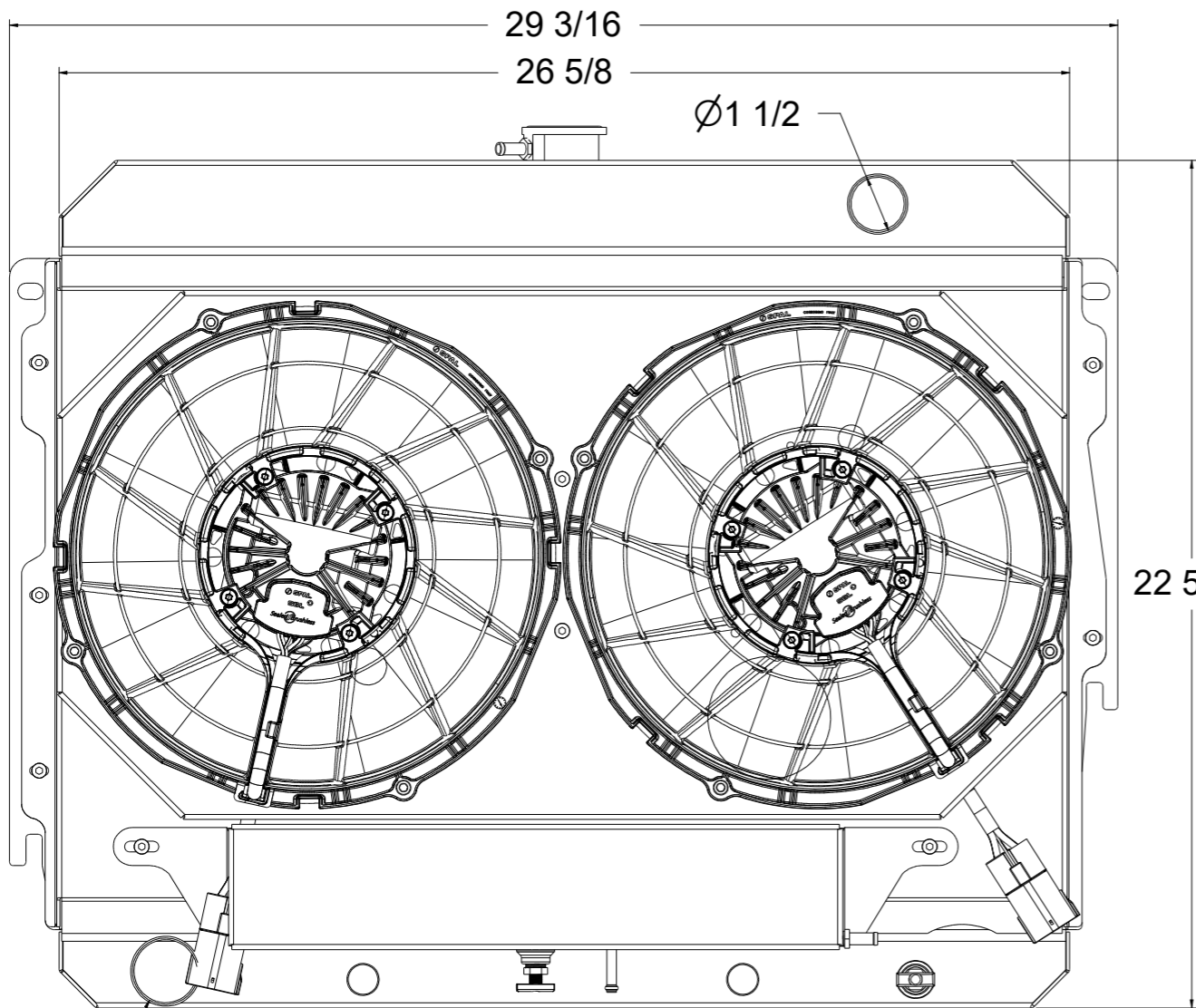
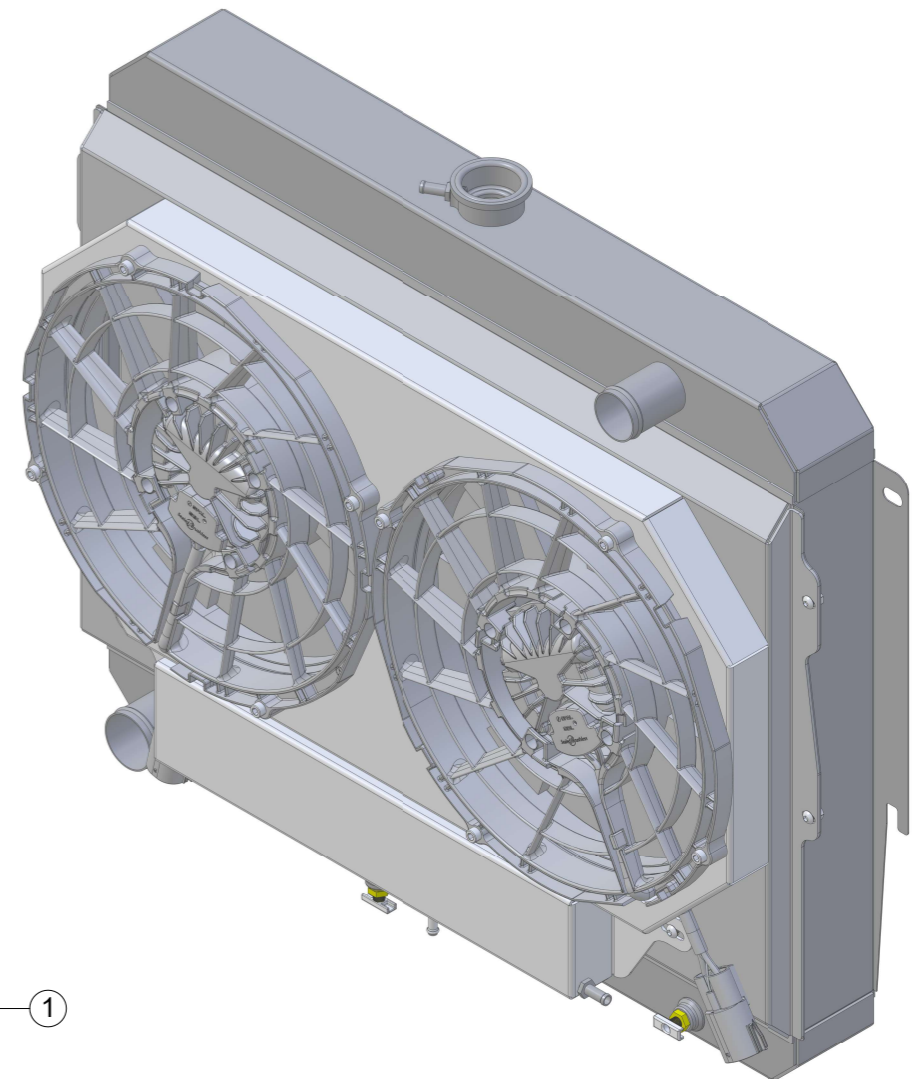
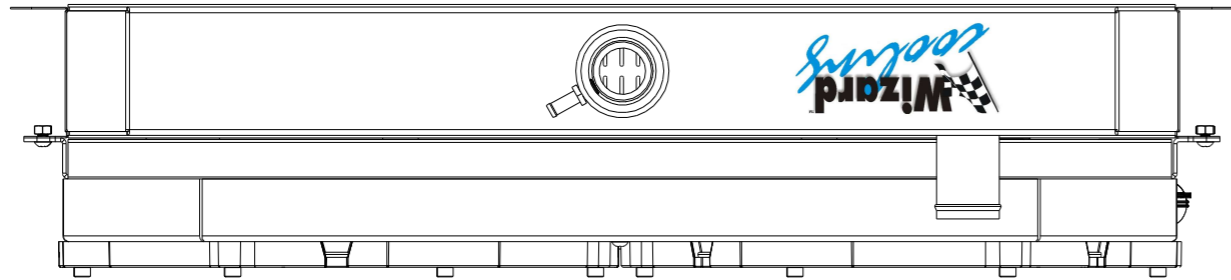

Item Number	Quantity	Part Number	Part Name	Revision	Comment
1	1	See Table	1640 Radiator		
2	2	See Table	1640 Brushless Fan Package w/ Expansion Tank		

	DRAWN	RM	DATE	01/16/25	Title: 1-1640-Radiator & 1-1640-002BLX
	CHECKED				
	QA				
	MFG				
APPROVED					SIZE: D FSCM NO.: DWG NO.: SCALE: 1:1 SHEET: