

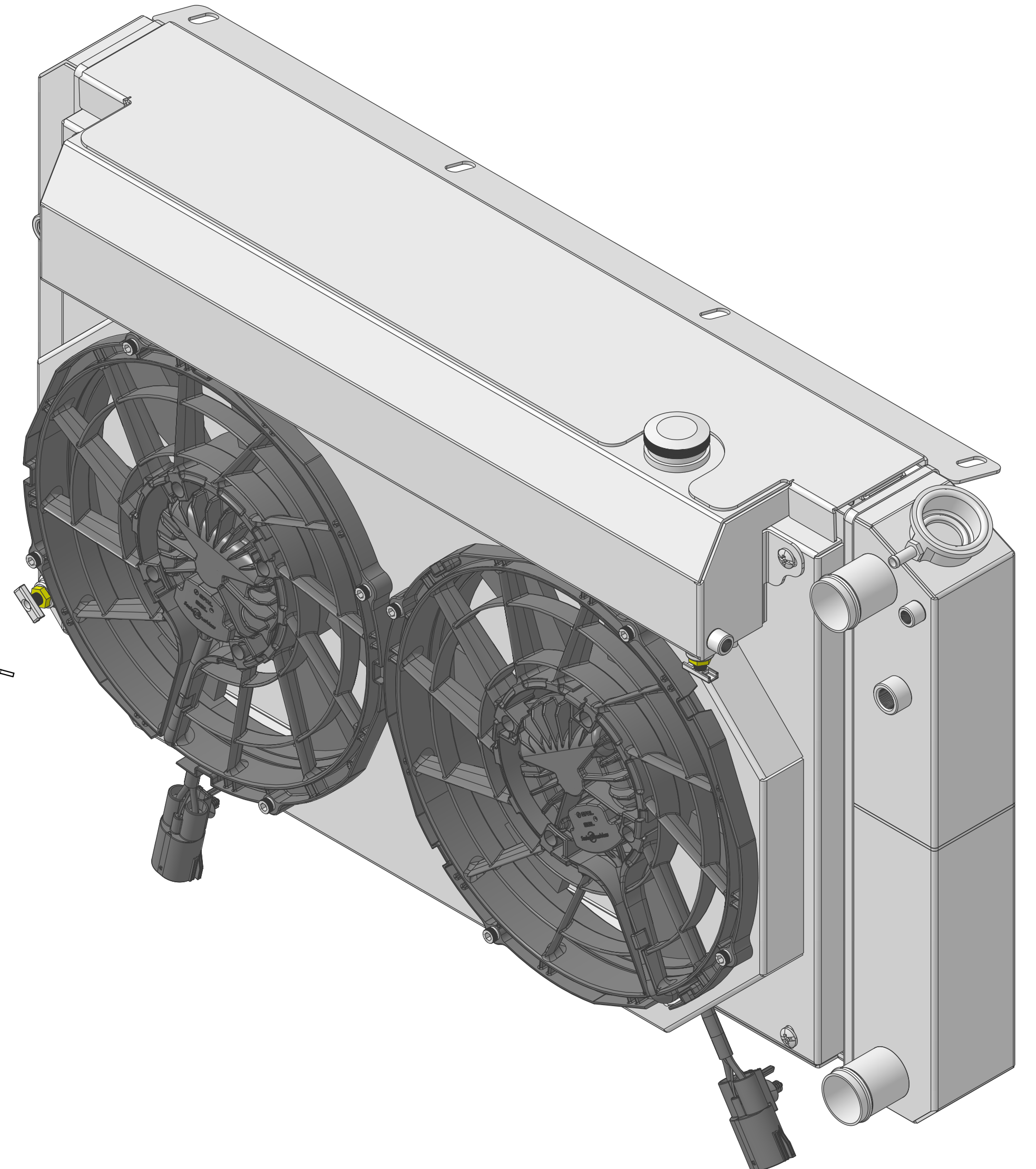

SKU #	Radiator DWG #	Radiator P/N	Transmission	Core Size	Shroud, Fan & X Tank DWG #	Shroud, Fan & X Tank P/N	Fan Type
1-361-112LTBLXR	1-361-LT Radiator	1-361-110LT	Automatic	STANDARD (2 Rows of 1" Tubes)	1-361-002BLXR & 1-361-Channels	1-361-002BL300225XR	12" 300 Watt Brushless
1-361-212LTBLXR		1-361-210LT		UPGRADED (2 Rows of 1.25" Tubes)		1-361-002BL300275XR	

REVISIONS				
ZONE	REV	DESCRIPTION	DATE	APPROVED

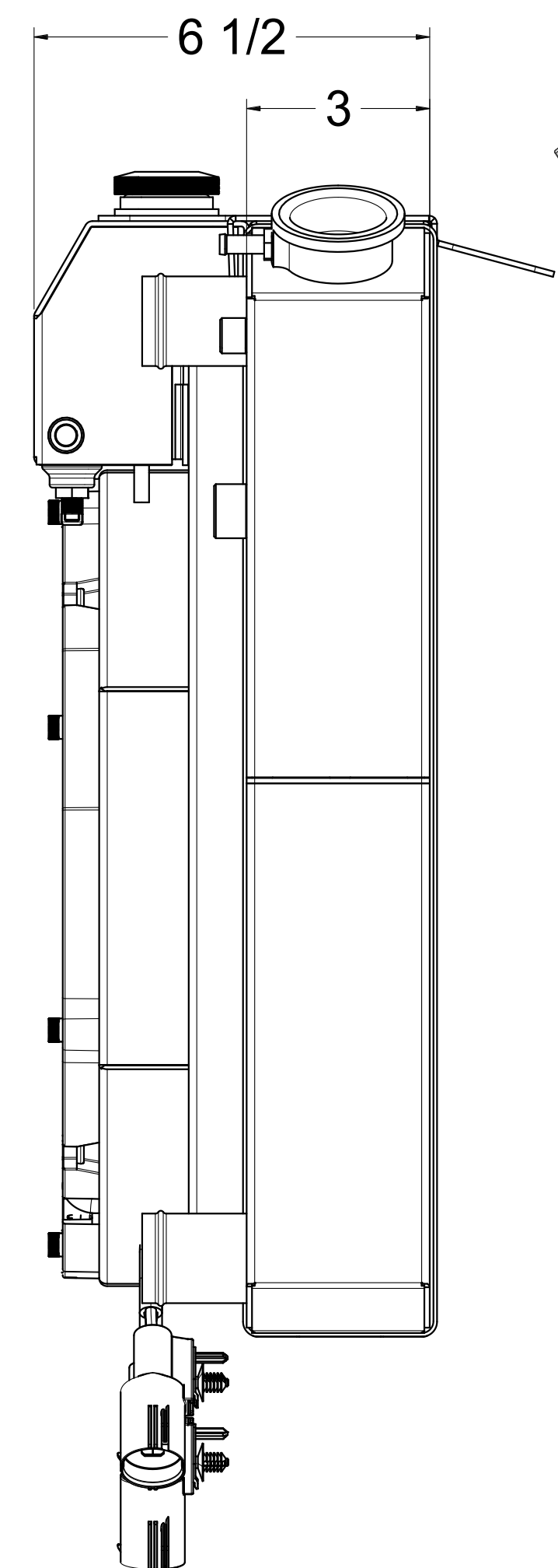
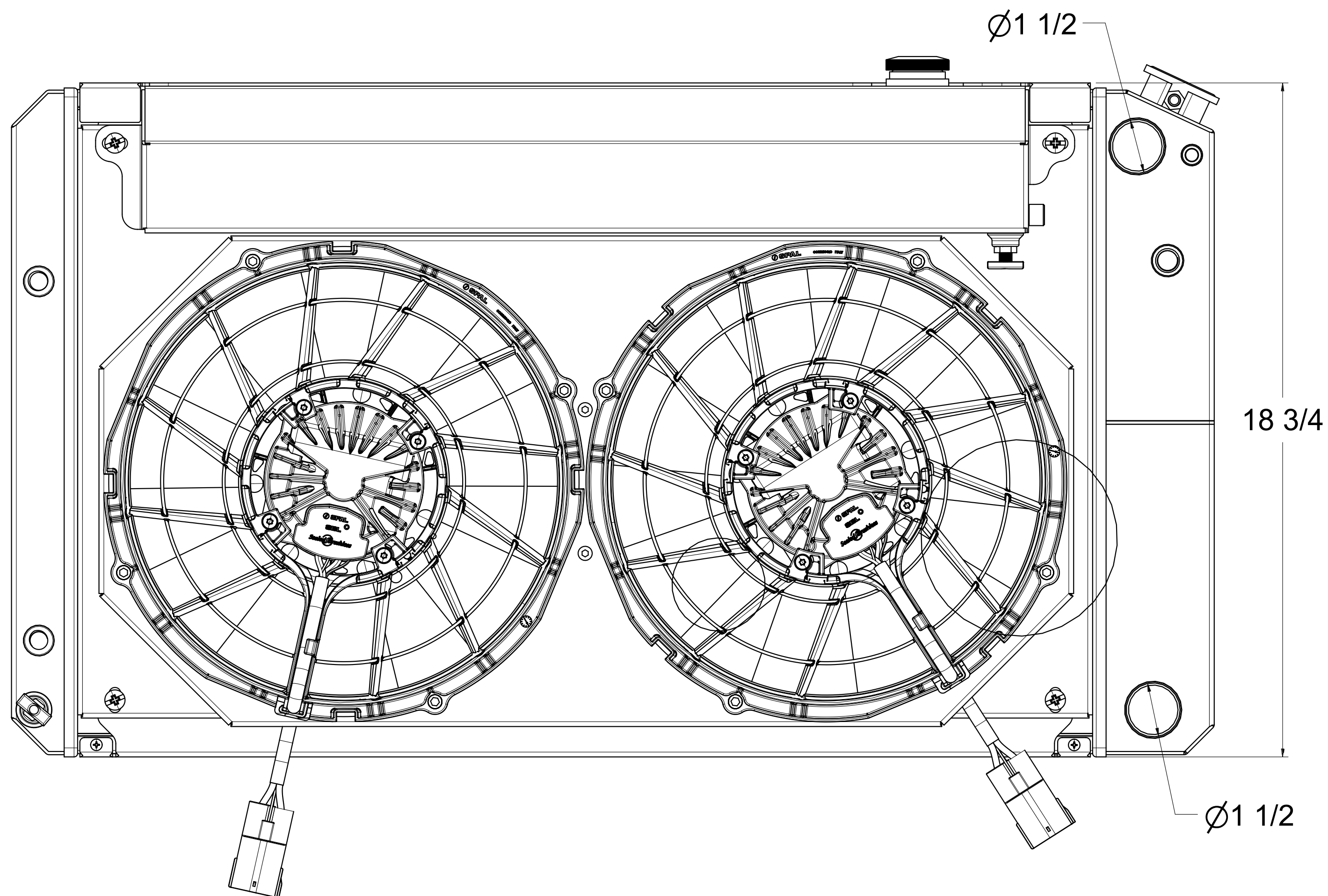
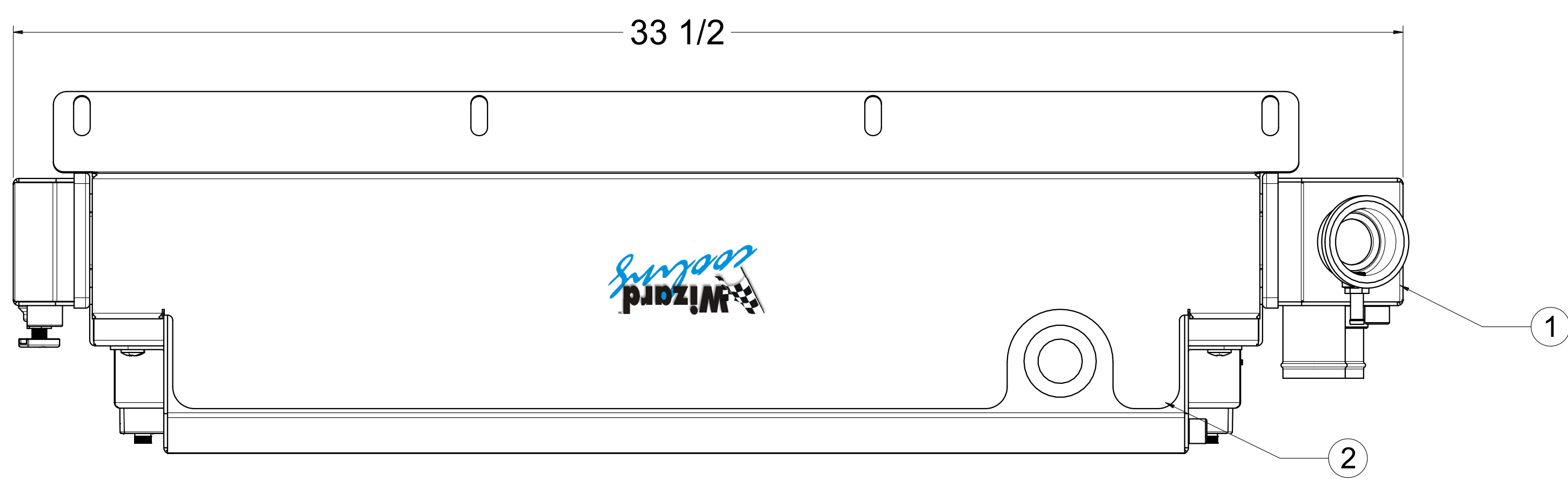

Item Number	Quantity	Part Number	Part Name	Revision	Comment
1	1	See Table "Radiator P/N"	361 LT Radiator (AT) Assembly		
2	1	See Table "Shroud, Fan & X Tank P/N"	361 BL Fan Shroud w/ Expansion Tank (for LT Swap Radiators)		

 <p>Custom Aluminum Radiators</p>	DRAWN	RM	DATE	08/15/25	Title: 1-361-LT Radiator Automatic Transmission & 1-361-002BLXR
	CHECKED				
	QA				
	MFG				
APPROVED					SIZE: D FSCM NO.: DWG NO.: SCALE: 1:1 SHEET: